

September 2022

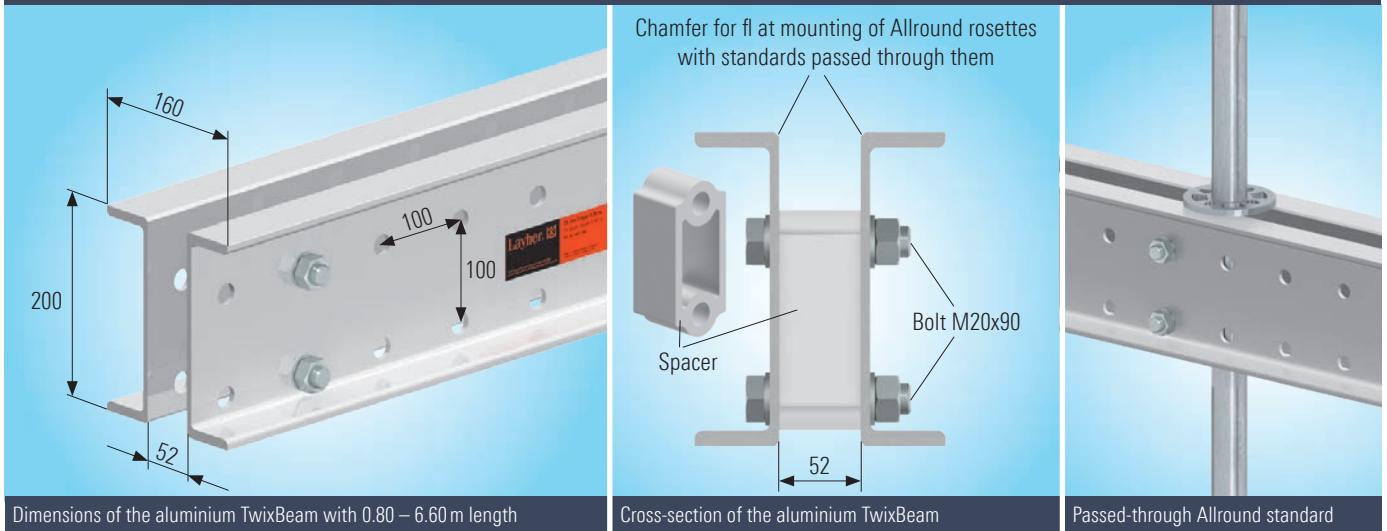

Dimensions of the aluminium TwixBeam with 0.80 – 6.60 m length

Cross-section of the aluminium TwixBeam

Passed-through Allround standard

LOW WEIGHT, EASY DISMANTLING AND HIGH STRENGTH

THE TWIXBEAM IN SCAFFOLDING CONSTRUCTION

The high-strength, multifunctional aluminium TwixBeam from Layher – consisting of two bolted aluminium U-sections with a height of 200 mm – has a wide range of possible uses, for wide-span work platforms, support beams, suspended scaffolding or projecting structures. The TwixBeam is available in lengths from 0.80 m to 6.60 m. The beam is characterised by high load-bearing capacity yet low weight.

There are many matching expansion parts available for the aluminium TwixBeam: The swivelling spindle is inserted into the 52 mm-wide intermediate area of the beam and pinned in place. It can be used as a head jack or base plate. Standard or suspended structures can be built by passing through an Allround standard or the swivelling spindle. The spindle strut (patent pending) permits stiffening or bracing of various structures – it can transmit tensile and compressive forces. Beam connector and insertion beam complete the system for flexible adaptability to all site conditions and contours.

Aluminium as the material ensures low weight in the beam. The bolted structure permits dismantling of the beam for different applications while ensuring that the material retains its maximum loading capacities and is not weakened by welding.

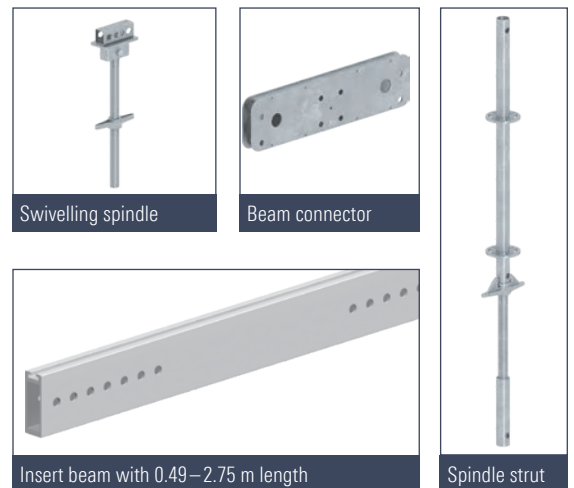

Swivelling spindle

Beam connector

Insert beam with 0.49–2.75 m length

Spindle strut

STRESS CAPACITIES

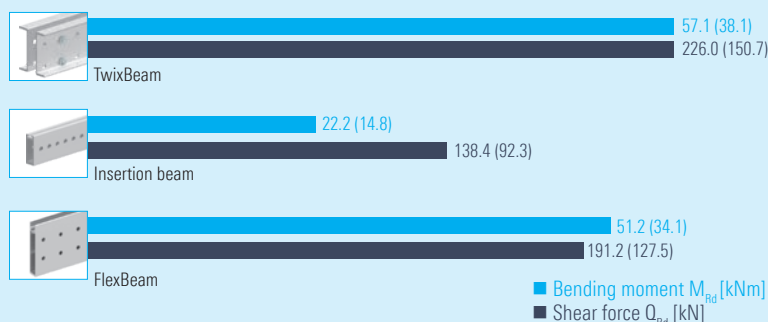

Note: Values in brackets are working loads ($\gamma_T = 1.5$). Serviceability and stability must be verified individually.

TECHNICAL DATA

	TwixBeam	Insertion beam
Height [mm]	200	140
Width [mm]	160	50
Weight [kg/m] – completely assembled	approx. 13.0	approx. 7.0
Bending stiffness EI [kNm ²] - gross	1760	440

GROUND ANCHORING

Instead of using ballast, scaffolding structures with the TwixBeam can also be anchored in the ground.

- ▶ Anchoring in the ground is achieved using threaded rods and matching plate nuts attached by others.
- ▶ This leads to enormous logistic benefits, since ballast weights do not have to be transported to the site and moved around there.
- ▶ The beam can, thanks to its bolted design, easily be dismantled into its individual parts and then reassembled. This permits subsequent attachment too.

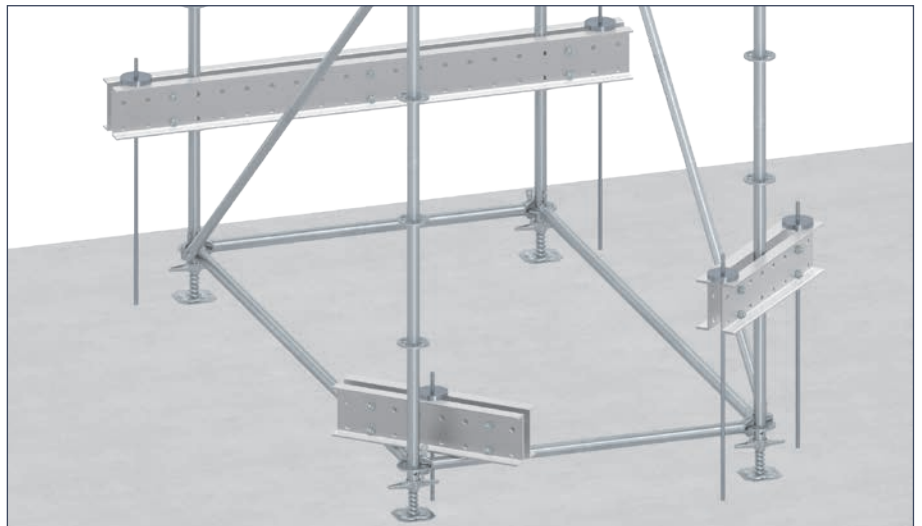

Tower scaffolding anchored in the ground

BRACKET APPLICATIONS

Where the ground is not sufficiently load-bearing, or where particularly material-saving scaffolding structures have to be built, the TwixBeam permits standard or suspended scaffolding to be assembled.

- ▶ Standard structures can be built with the All-round standards passed through or with the swivelling TwixBeam spindle.
- ▶ Projecting structures in unfinished buildings can have two designs: anchored to the slab or in the ground, or braced against the slab.
- ▶ To provide grid platform structures, the TwixBeams can be mounted one above the other. Connection is by beam clamps.
- ▶ To increase the loading capacity, the beams can also be mounted one above the other in the same direction. They are secured using beam clamps or by an offset arrangement of the spacer.

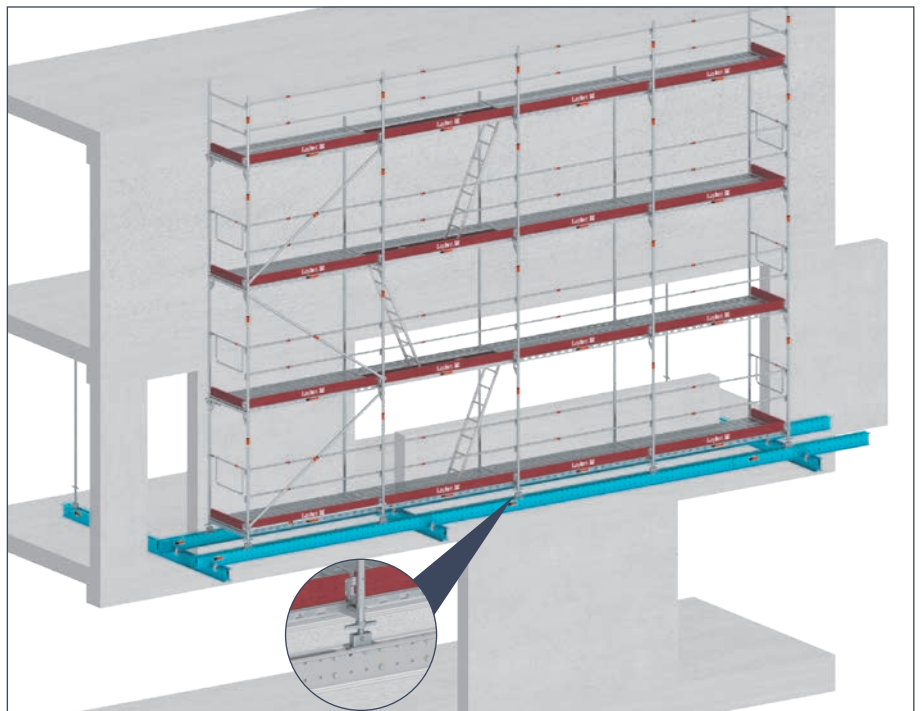

Standard bracket scaffolding – TwixBeam structure assembled as a grid – braced against slab

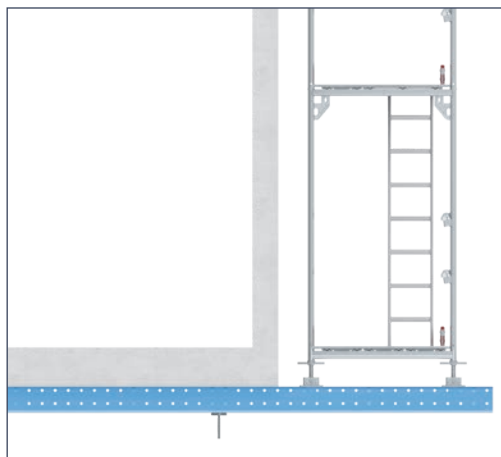

Bracket scaffolding anchored to the slab

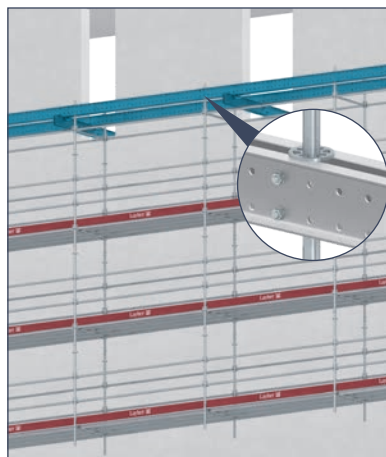

Suspended bracket scaffolding

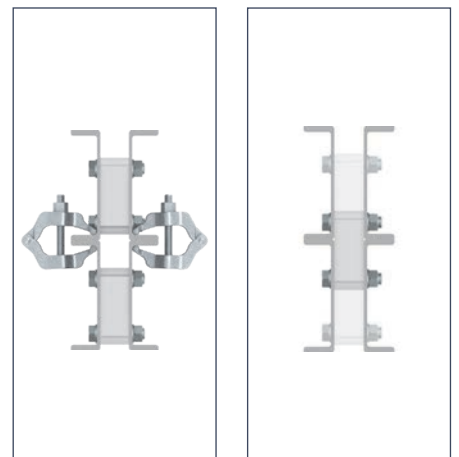

Beams placed one above the other secured using beam clamps (left) or with the spacer (right)

STAIKTOWER SUSPENSION

For many site requirements it may be necessary to assemble staitowers suspended, from the top downwards.

- ▶ The supporting structure is easily made by spanning the cutout in the slab using the TwixBeam.
- ▶ Suspension is achieved simply by passing through the Allround standards and placing the rosette on the TwixBeam.
- ▶ Other scaffolding structures at slab cutouts can be suspended in the same way.

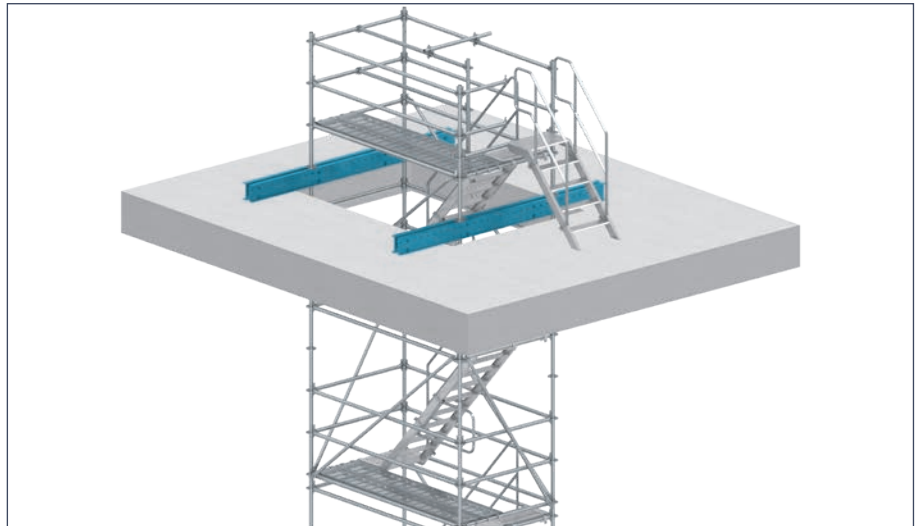

Suspended Allround modular staitower

PLATFORM SOLUTIONS

The TwixBeam can be used to create solutions with projecting platforms or platforms supported on both sides.

- ▶ Projecting platforms can either be anchored in the ground or braced against the slab.
- ▶ For standard mounting, the swivelling TwixBeam spindle is used for the spindle base.
- ▶ Combination with the aluminium FlexBeam permits the building of hybrid platform structures.

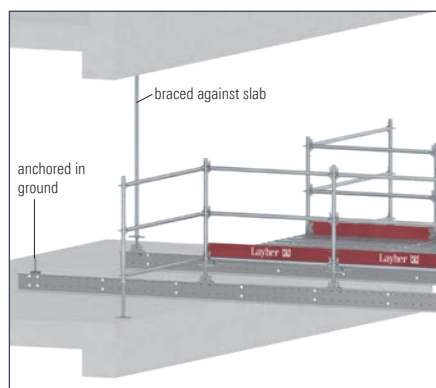

Projecting platform – anchored and braced against slab

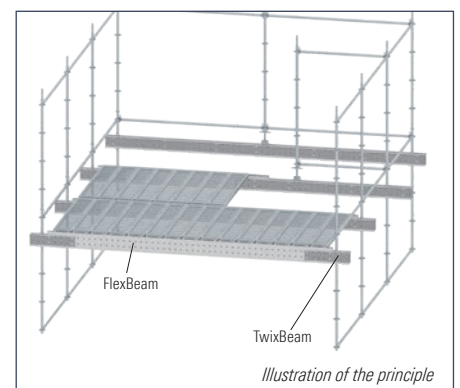

Platform as hybrid structure of TwixBeam and FlexBeam

VARIABLE BEAM STRUCTURES

- ▶ The uniform hole configurations in the TwixBeam, the insertion beam and the FlexBeam permit a variety of beam structures.
- ▶ The beams can be assembled straight, oblique or at right angles.
- ▶ This means flexible adjustments can be made, for example to match funnel-like boiler contours.

THE BENEFITS FOR YOU:

- ▶ Low-weight, easily dismantled and high-strength aluminium beam – particularly useful when passing material through narrow manholes.
- ▶ Bracket applications and bracing structures achievable within the system.
- ▶ High variability thanks to the insertion beam and combination with the aluminium FlexBeam.
- ▶ Investments protected thanks to weather resistance and frequent reusability.
- ▶ Easy angle adjustment using swivelling spindle.

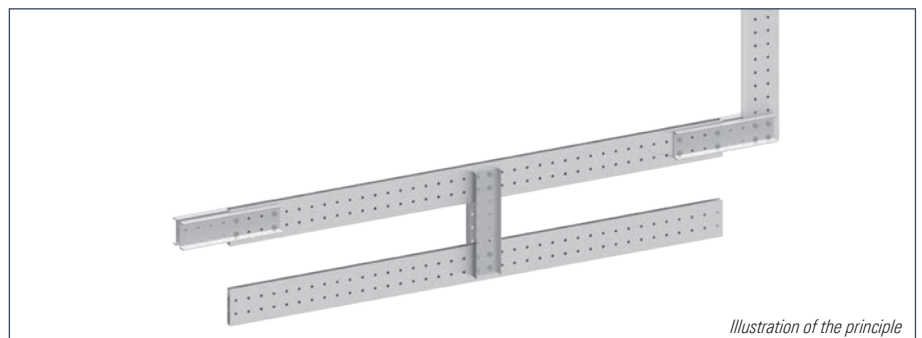

Hybrid beam structure with FlexBeam and TwixBeam

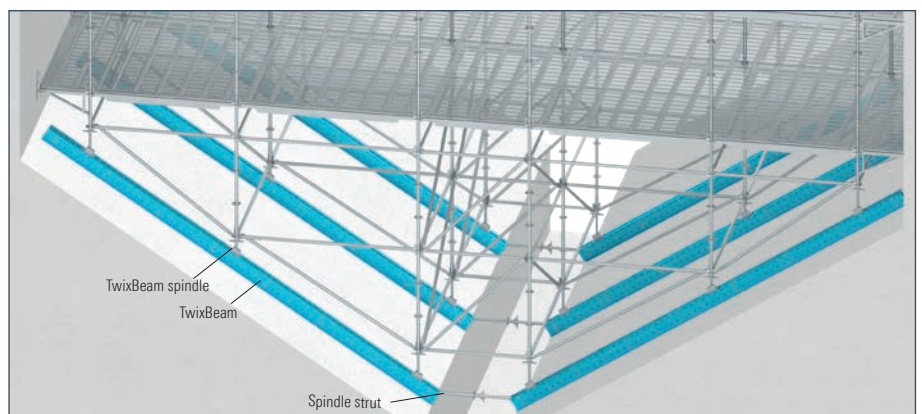

Beam structure for adjustment to funnel-like boiler

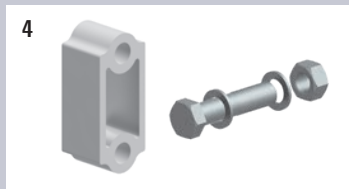
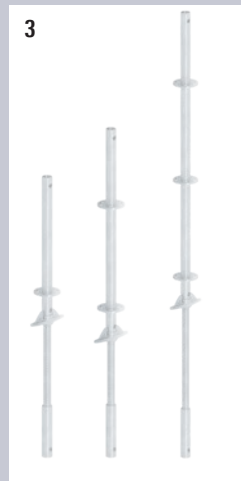
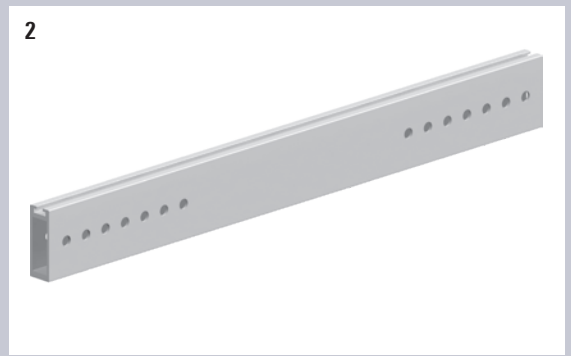

Pos.	Description	Dimensions L/H x W [m]	Weight approx. [kg]	PU [pcs.]	Ref. No.
1	TwixBeam aluminium completely assembled, with spacer, bolts and nuts	0.80	11.6	20	4041.080
		1.70	23.1	20	4041.170
		2.10	27.6	20	4041.210
		2.60	34.6	20	4041.260
		3.10	40.3	20	4041.310
		3.60	47.3	20	4041.360
		4.60	60.0	20	4041.460
		5.60	72.6	20	4041.560
		6.60	85.3	20	4041.660
2	TwixBeam insertion beam	0.49	3.4	30	4042.049
		0.91	6.3	30	4042.091
		1.27	8.9	30	4042.127
		1.75	12.4	30	4042.175
		2.25	15.9	30	4042.225
		2.75	19.5	30	4042.275
3	Spindle strut	0.90 – 1.30	11.0	50	4043.130
		1.20 – 1.80	15.3	50	4043.180
		1.70 – 2.30	18.1	50	4043.230
4	Spacer Bolt M20 x 90 with nut		0.5	250	4041.000
			3.8	10	4041.004
5	TwixBeam beam connector	0.80	16.4	50	4041.001
6	Articulated TwixBeam spindle 60 solid	0.60	8.2	100	4041.002
7	Standard connection	0.54	2.3	100	4041.003
8	Wall Fixing for TwixBeam	0.30 x 0.25 x 0.17	10.3	1	4041.005
9	Wall Fixing for TwixBeam insertion beam	0.30 x 0.25 x 0.15	10.5	1	4041.006
10	Threaded spindle and standard adapter	0.32 x 0.15 x 0.05	2.9	1	4041.007
11	TwixBeam stopper	0.15 x 0.13 x 0.09	2.7	1	4041.008
12	Beam clamp for insertion beam, with groove bolt	0.08 x 0.04 x 0.07	0.3	1	4041.010

PU = packaging unit available ex plant warehouse only available in this packaging unit delivery time on request package price per PU

Subject to technical modification. Component weights are subject to fluctuations due to tolerances and may therefore diverge from what is specified.
Deliveries shall be made exclusively in accordance with our currently valid General Terms of Sale. Some of the scaffolding structures shown may still be undergoing assembly.